



Sticks form part of our wide range of filler metals for soft soldering. These products are used for applications such as building and all types of manufacturing. Waste originating from the use of these products can be recycled.

The sticks are made from primary quality metals. Their shape is particularly suited to plumbing work, accessories for sheet metal work and car bodywork. They are also suitable for industrial use in the assembly of various metals such as copper, brass, tin and zinc. The METACONCEPT Group collects used baths, off-cuts, scraps and white metal oxides. [Contact our recycling department](#) to find out more.

Characteristics

This table shows the most commonly used alloys. For other types of alloys, [please contact our technical department](#).

Item no.	Designation	Composition	Dimensions	Density g/cm ³	Solidus / Liquidus °C	Approximate weight	Packaging
FE055012	Stick META 28	Sn28 - Pb72	340 x 910 x 12 mm	10.21	183°C - 253°C	224 g	25 kg bundle
FE055014	Stick META 30	Sn30 - Pb70	340 x 10 x 12 mm	10.13	183°C - 250°C	222 g	25 kg bundle
FE054994	Stick META 33	Sn33 - Pb67	340 x 10 x 12 mm	10.01	183°C - 243°C	226 g	25 kg bundle
FE054991	Stick META-ZINC	Sn - Pb + additives	340 x 10 x 12 mm	10.15	183°C - 245°C	223 g	25 kg bundle
FE055017	Stick META 40	Sn40 - Pb60	340 x 10 x 12 mm	9.72	183°C - 235°C	213 g	25 kg bundle
FE028977	Stick Sn50	Sn50 - Pb50	340 x 10 x 12 mm	9.32	183°C - 210°C	205 g	25 kg bundle
FE028980	Stick Sn60	Sn60 - Pb40	340 x 10 x 12 mm	8.91	183°C - 190°C	195 g	25 kg bundle
MF100041	Triangular stick*	Sn70 - Zn30	13 x 13 x 10 x 450 mm	7.25	199°C - 320°C	159 g	25 kg bundle
FE028962	Trapezoidal stick OTALINE	Sn - Pb - Zn	450 x 10 x 4 x 7 mm	9.51	170°C - 179°C	209 g	20 kg bundle
FE100050	Triangular stick*	Sn95 - Ag5	450 x 7 x 7 mm	7.45	221°C - 223°C	163 g	25 kg bundle
FE100001	Half-round spun stick	Sn96.5 - Ag3.5	500 x 10 x 12 mm	7.4	221°C - 230°C	181 g	20 kg bundle
FE028964	Triangular stick*	Sn100	450 x 7 x 7 mm	7.28	232°C	160 g	20 kg bundle

(*) Lead-free alloys - European standard no. 2000 / 53 / CE

The dimensions and weights are given for informational purposes only and may vary depending on the production run.

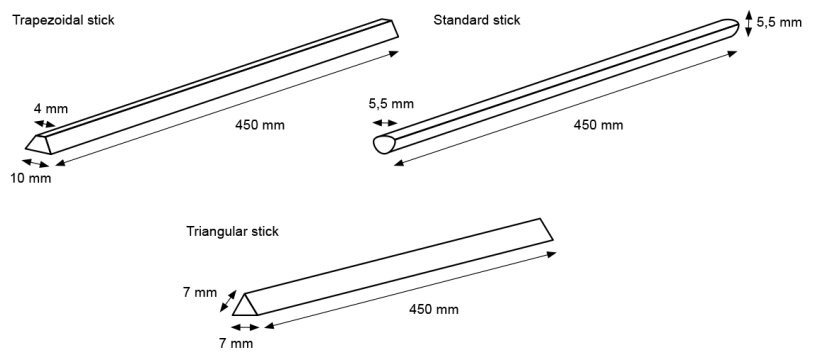

Applications

Sn28 – Sn30 – Sn33 sticks

Plumbing, tinware, car bodywork, tinning baths, sheet metal work, coverings.

Sn40 sticks

Heating, assembly of mechanical parts

Sn50 – Sn60 sticks

Creating of and filling tinning baths, assembly of mechanical parts.

Sn100 sticks

Casting, surface treatments including tinning cookware, brassware.

Sn40 sticks

Sheet metal work, coverings, assembly of mechanical parts

Otaline sticks

Used on aluminium and its alloys. Apply Aluflux flux for this application.

Implementation

The product safety datasheet below is available on request from the METACONCEPT Group.

The parts to assemble must be clean (deoxidised and degreased). Apply the appropriate flux to the parts.

Heat the parts using a propane or acetylene torch, or a soldering iron.

The parts must be brought to a temperature of around 15 to 20°C below liquidus.

Melt the filler metal onto the parts being assembled to form a regular bead.

Allow the parts to cool without moving them.

When the parts have returned to room temperature, brush the soldering beads using a metallic brush. If necessary, clean the assembly with clean water or water with a touch of citric or formic acid (1 to 2%).

Precautions for use

To prevent burns caused by the molten metal, it is advisable to wear a protective apron, shoes, gloves, helmet and glasses.

Do not smoke at the workstation.

The workstation must be well ventilated.

Wash your hands when leaving the workstation.

Comments:

Always use a flux suited to the intended use. [Contact our technical department](#) to ascertain which product is most suited to your application.

All of the information contained in this document is provided for informational purposes only and the METACONCEPT Group will not be held liable for it.